

# Feterl

## 8" & 10" Red & Commercial HYDRA-FEED AUGERS With Ground Hugger Hopper

Cable trussed for additional strength • Scissor design undercarriage - proven most stable  
Tapered wheel bearing in agricultural hubs • Jack stand for easy hook-up • Hydraulic worm winch  
Hydraulically driven hopper • Hopper feeds from left or right • Has wheels for easy swing  
Hopper is lifted for transport by a ratchet winch

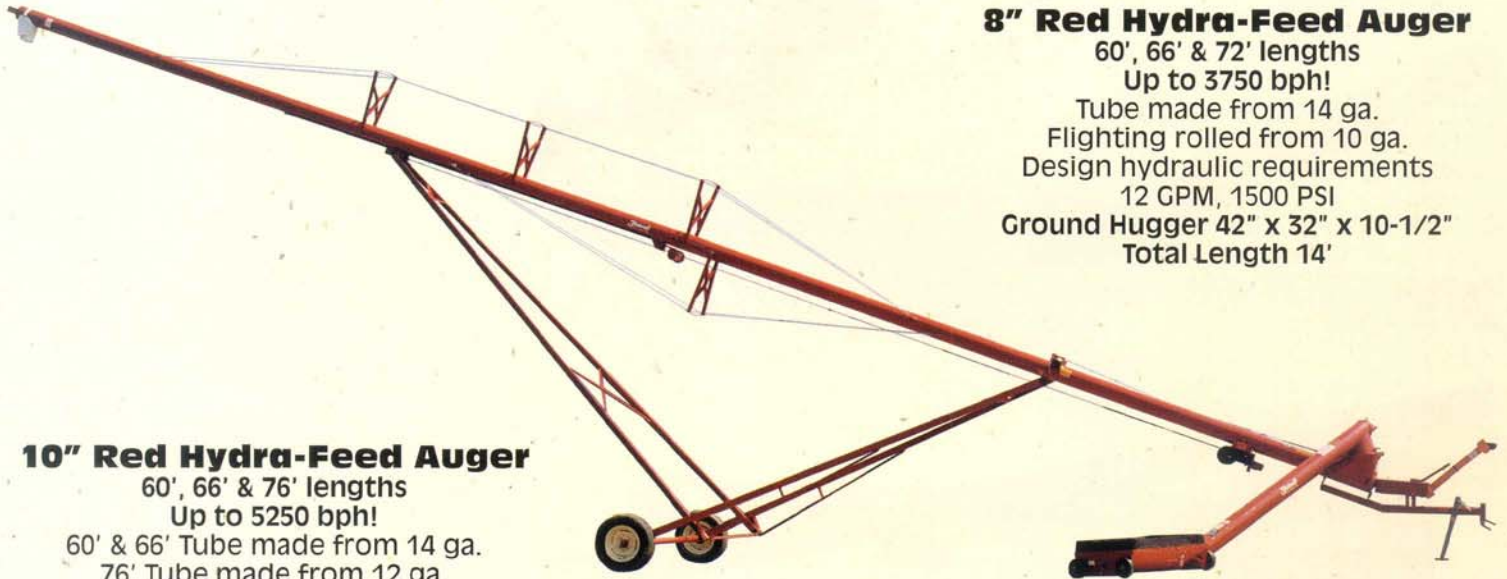

### 8" Red Hydra-Feed Auger

60', 66' & 72' lengths

Up to 3750 bph!

Tube made from 14 ga.

Flighting rolled from 10 ga.

Design hydraulic requirements

12 GPM, 1500 PSI

Ground Hugger 42" x 32" x 10-1/2"

Total Length 14'

### 10" Red Hydra-Feed Auger

60', 66' & 76' lengths

Up to 5250 bph!

60' & 66' Tube made from 14 ga.

76' Tube made from 12 ga.

Flighting rolled from 7 ga.

Design hydraulic requirements

12 GPM, 1800 PSI

Ground Hugger 60" x 32" x 10-1/2"

Total Length 15'6"

### 10" Commercial Hydra-Feed Auger

60', 66' & 76' lengths

Up to 5250 bph!

Tube made from 12 ga.

Flighting rolled from 1/4" strip

Design hydraulic requirements

12 GPM, 1800 PSI

Ground Hugger 60" x 32" x 10-1/2"

Total Length 15'6"

### A Feterl Innovation ... VERSA-MOUNT SYSTEM

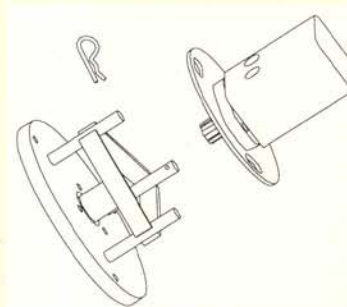

One hydraulic motor with  
VERSA-MOUNT separately oper-  
ates hopper or worm winch lift.  
The VERSA-MOUNT system  
requires only two hydraulic  
hoses for either operation so  
there is no need for dual out-  
lets on tractor. Quickly change  
hydraulic motor from hopper to  
worm winch lift or vice versa  
with the VERSA-MOUNT.

### FETERL GROUND HUGGER HOPPER

The hopper that fits under your semi-trailer even when the  
auger is on the bin! Our special flight design, coupled with a  
special CV joint, creates a pivot that enables the hopper tube  
to raise while the hopper opening remains flat on the ground.

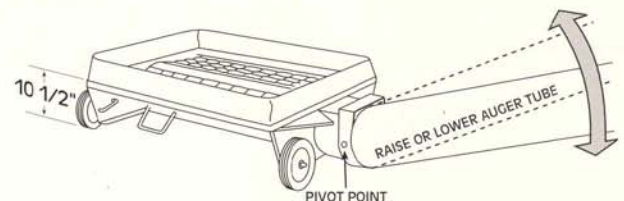

**MADE IN THE U.S.A.**

# Feterl

## 8" & 10" Red & Commercial HYDRA-FEED AUGERS With Ground Hugger Hopper



Standard Discharge  
Relief Spout

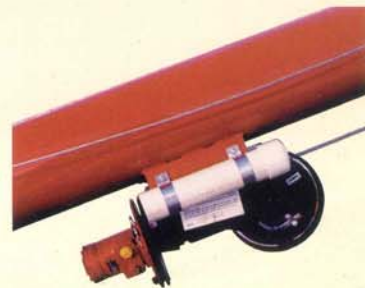
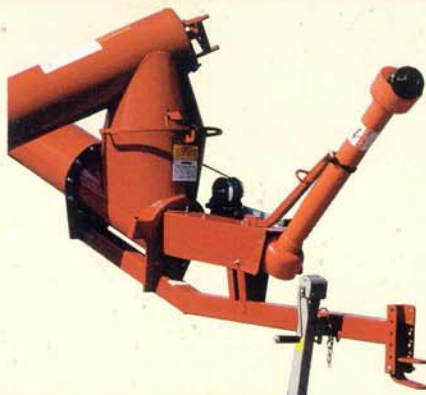

Hydraulic motor powers the worm winch lift, lifting and lowering at a smooth, steady pace.



OPTIONAL: Perforated section in hopper 60" long, with cover.

### A FETERL INNOVATION...

The hopper construction is the first to use the ball and socket connection for total seal. There is full and unrestricted movement from right or left feeding position at any elevation. No intake boot with edges, ledges or corners to crack kernels. Feterl's hopper discharges directly into the tube.



Hydra-Feed Hopper in Transport Position

Direct drive PTO with shear pin

Hitch adjustment provides easy alignment of universal joints for long life and smooth running

### SPECIFICATIONS

NOTE TRANSPORT HEIGHT AND ALLOW FOR ADEQUATE CLEARANCE UNDER POWER LINES AND OTHER OBSTRUCTIONS.

#	A TUBE LENGTH	B MAX.	C MAX.	D MAX.	E MAX.	TRANSPORT HEIGHT	MINIMUM TRACTOR PTO HP	MAX. BPH DRY WHEAT
8-60	54'6"	40'6"	20'	21'2"	20'	11'	30	3750
8-66	60'6"	43'6"	20'	24'	20'	12'	35	3750
8-72	66'6"	50'	25'	25'	25'	15'3"	40	3750
10-60 R	54'8"	40'6"	20'	21'2"	20'	11'	50	5250
10-66 R	60'2"	43'6"	20'	24'	20'	12'	55	5250
10-76 R	70'8"	48'	24'	25'	24'	15'6"	60	5250
10-60 C	56'3"	40'6"	20'	21'2"	20'	11'	50	5250
10-66 C	61'9"	43'6"	20'	24'	20'	12'	55	5250
10-76 C	72'2"	48'	24'	25'	24'	15'6"	60	5250

# Standard auger equivalent length.

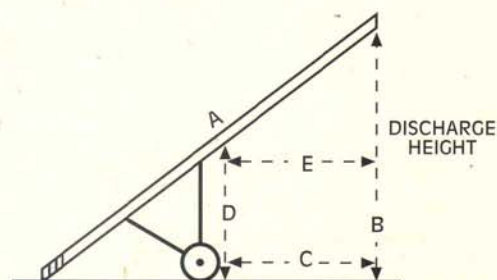

### WIDE WHEEL TRACK FOR STABILITY

60' & 66' Augers have 108" wheel track  
72' & 76' Augers have 114" wheel track

Manufactured by:

**Feterl**  
MFG. CO.

A United Dominion Company  
Salem, South Dakota 57058

PHONE: (605) 425-2206 • FAX: (605) 425-2183

TOLL FREE: (800) 367-8660

www.feterl.com

Contact Us For Specific Information